

HORIZONTAL PUMPSETS – GENERAL DESCRIPTION

As a standard, these pumpsets are built with various capacities and they are composed of:

- A horizontal welded sheet steel tank with perfect vacuum seal.
- A rotating vane vacuum pump to be selected according to the required suction capacity and vacuum degree.
- A vacuum switch for adjusting the vacuum level within which to operate.
- A vacuum gauge for a direct reading of the vacuum level in the tank.
- A switchgear enclosed in a special plastic casing for tanks from 25 to 50 litres and in a watertight metal casing for tanks of 100 litres upwards.
- A manual valve for vacuum interception.
- A cock for condensation drainage.

The vacuum level, preset via the mini vacuum switch is automatically maintained in the tank. The pump operation can be both continuous or automatic.

Pumpsets are normally used for handling particularly heavy or valuable loads since, in case of electricity failure, they allow the vacuum cups to maintain the grip for a certain amount of time, according to the tank capacity.

These pumpsets are recommended for multi-point applications, to centralise vacuum.

These pumpsets offer many advantages in energy consumption, since the pump operates only when required by the machine.



HORIZONTAL PUMPSETS DO 25 ...

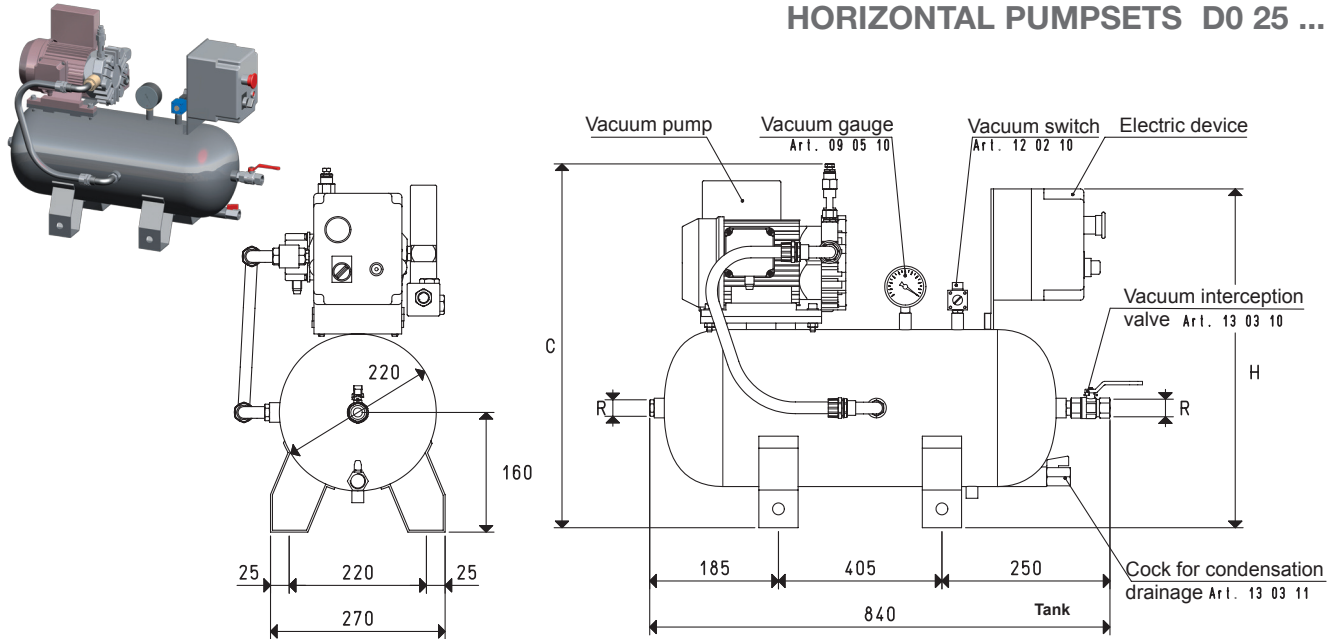

Art.	Tank	Pump	Motor execution	Switchgear	C	H	R	Weight	Filter accessories
	Litres	Mod.	Volt	art.			∅	Kg	art.
DO 25 VTL 5	25	VTL 5	3 ~ 230/400-50Hz	DO 06 92	540	450	G1/2"	33.5	FB 20 / FC 20
DO 25 VTL 5 M	25	VTL 5 M	1 ~ 230/50Hz	DO 06 90	540	450	G1/2"	34.0	FB 20 / FC 20
DO 25 VTL 6 CC	25	VTL 6 CC	= 24-CC	DO 06 93	480	450	G1/2"	29.3	FB 20 / FC 20
DO 25 VTL 10	25	VTL 10	3 ~ 230/400-50Hz	DO 06 92	540	450	G1/2"	39.5	FB 20 / FC 20
DO 25 VTL 10 M	25	VTL 10 M	1 ~ 230-50Hz	DO 06 90	540	450	G1/2"	40.0	FB 20 / FC 20

Note: By adding the letters SR, the pumpset will be supplied with wheels (E.g.: DO 25 VTL 10 SR).

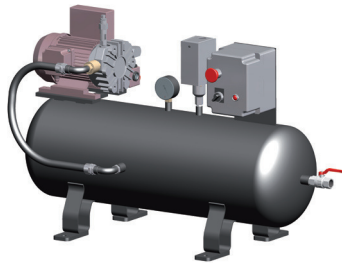

HORIZONTAL PUMPSETS DO 50 ...

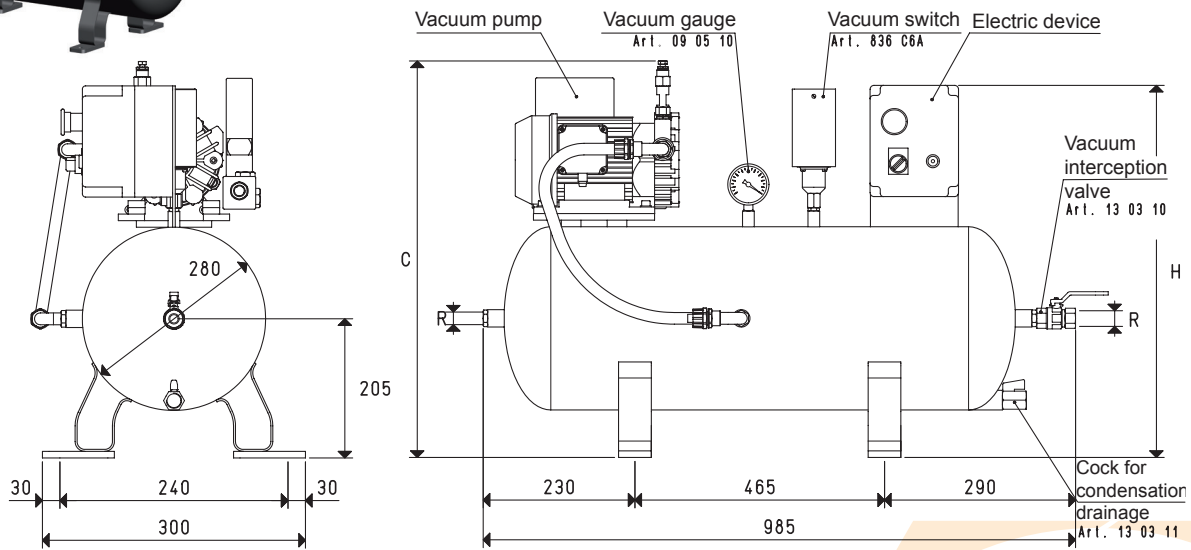

Art.	Tank	Pump	Motor execution	Switchgear	C	H	R	Weight	Filter accessories
	Litres	Mod.	Volt	art.			∅	Kg	art.
DO 50 VTL 5	50	VTL 5	3 ~ 230/400-50Hz	DO 06 92	620	530	G1/2"	39.3	FB 20 / FC 20
DO 50 VTL 5 M	50	VTL 5 M	1 ~ 230/50Hz	DO 06 90	620	530	G1/2"	39.8	FB 20 / FC 20
DO 50 VTL 6 CC	50	VTL 6 CC	= 24-CC	DO 06 93	570	530	G1/2"	35.1	FB 20 / FC 20
DO 50 VTL 10	50	VTL 10	3 ~ 230/400-50Hz	DO 06 92	620	530	G1/2"	45.3	FB 20 / FC 20
DO 50 VTL 10 M	50	VTL 10 M	1 ~ 230-50Hz	DO 06 90	620	530	G1/2"	45.8	FB 20 / FC 20

Note: By adding the letters SR, the pumpset will be supplied with wheels (E.g.: DO 50 VTL 10 SR).

Conversion ratio: inch = $\frac{\text{mm}}{25.4}$; pounds = $\frac{\text{g}}{453.6}$ = $\frac{\text{Kg}}{0.4536}$

GAS-NPT thread adapters available at page 1.117

7.73

3D drawings available at www.vuotecnica.net

HORIZONTAL PUMPSETS DO 100 ...

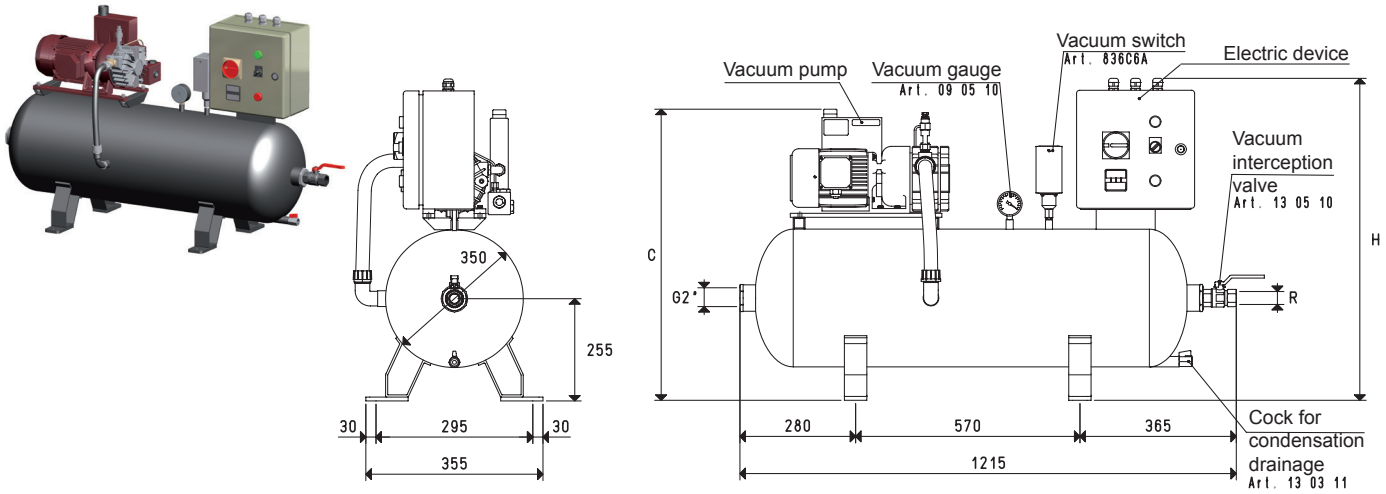

Art.	Tank	Pump	Motor execution	Switchgear	C	H	R	Weight	Filter accessories
	Litres	Mod.	Volt	art.			∅	Kg	art.
DO 100 VTL 10/F	100	VTL 10/F	3 ~ 230/400-50Hz	DO 100 90	710	800	G1"	66.7	FB 30 / FC 30
DO 100 VTL 10/F M	100	VTL 10/F M	1 ~ 230/50Hz	DO 100 89	710	800	G1"	68.2	FB 30 / FC 30
DO 100 VTL 15/F	100	VTL 15/F	3 ~ 230/400-50Hz	DO 100 90	710	800	G1"	68.7	FB 30 / FC 30
DO 100 VTL 15/F M	100	VTL 15/F M	1 ~ 230-50Hz	DO 100 89	710	800	G1"	70.2	FB 30 / FC 30
DO 100 VTL 20/F	100	VTL 20/F	3 ~ 230/400-50Hz	DO 100 90	710	800	G1"	71.7	FB 30 / FC 30
DO 100 VTL 20/F M	100	VTL 20/F M	1 ~ 230-50Hz	DO 100 89	710	800	G1"	73.2	FB 30 / FC 30
DO 100 MV 20	100	MV 20	3 ~ 230/400-50Hz	DO 100 90	681	800	G1"	62.2	FB 30 / FC 30
DO 100 MV 20 M	100	MV 20 M	1 ~ 230-50Hz	DO 100 89	681	800	G1"	64.7	FB 30 / FC 30

Note: By adding the letters SR, the pumpset will be supplied with wheels (E.g.: DO 100 VTL 15/F S)

HORIZONTAL PUMPSETS DO 150 ...

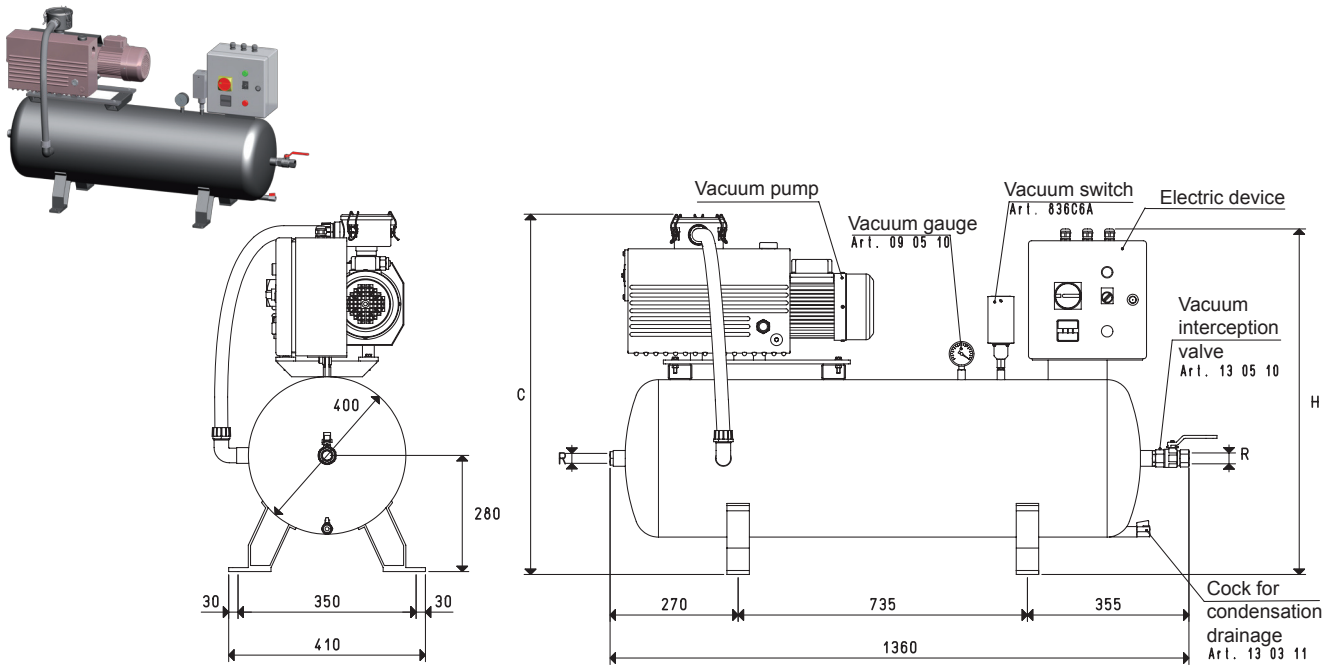

Art.	Tank	Pump	Motor execution	Switchgear	C	H	R	Weight	Filter accessories
	Litres	Mod.	Volt	art.			∅	Kg	art.
DO 150 VTL 25/FG	150	VTL 25/FG	3 ~ 230/400-50Hz	DO 100 90	805	840	G1"	79.0	FB 30 / FC 30
DO 150 VTL 30/FG	150	VTL 30/FG	3 ~ 230/400-50Hz	DO 100 90	805	840	G1"	83.0	FB 30 / FC 30
DO 150 VTL 35/FG	150	VTL 35/FG	3 ~ 230/400-50Hz	DO 100 90	805	840	G1"	85.0	FB 30 / FC 30
DO 150 MV 40	150	MV 40	3 ~ 230/400-50Hz	DO 100 90	916	840	G1"	93.0	FB 30 / FC 30
DO 150 VTL 50/G1	150	VTL 50/G1	3 ~ 230/400-50Hz	DO 100 90	880	840	G1"	102.0	FB 30 / FC 30
DO 150 MV 60	150	MV 60	3 ~ 230/400-50Hz	DO 100 90	916	840	G1"	101.0	FB 30 / FC 30
DO 150 VTL 75/G1	150	VTL 75/G1	3 ~ 230/400-50Hz	DO 100 90	930	840	G1"	118.5	FB 30 / FC 30

Note: By adding the letters SR, the pumpset will be supplied with wheels (E.g.: DO 150 VTL 30/FG SR).

As a standard, all MV... pumps are equipped with an FC... filtre adjusted to the suction connection size.

3D drawings available at www.vuototecnica.net

HORIZONTAL PUMPSETS DO 300 ...

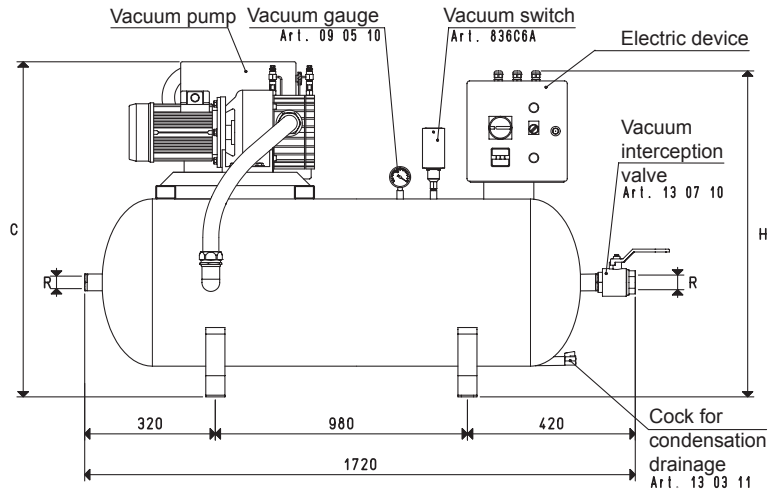
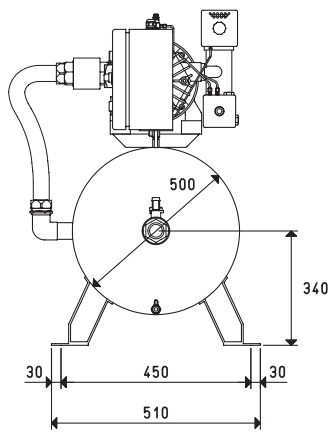
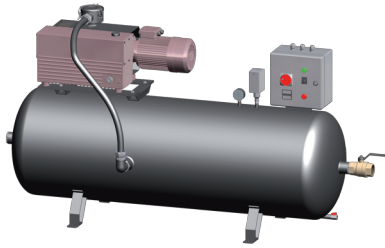

Art.	Tank	Pump	Motor execution	Switchgear	C	H	R	Weight	Filter accessories
	Litres	Mod.	Volt	art.			∅		Kg
DO 300 MV 60	300	MV 60	3 ~ 230/400-50Hz	DO 100 90	940	940	G1"1/2	135.3	FB 50 / FC 50
DO 300 VTL 75/G1	300	VTL 75/G1	3 ~ 230/400-50Hz	DO 100 90	1040	940	G1"1/2	153.3	FB 50 / FC 50
DO 300 MV 100	300	MV 100	3 ~ 230/400-50Hz	DO 100 90	970	940	G1"1/2	162.3	FB 50 / FC 50
DO 300 VTL 105/G1	300	VTL 105/G1	3 ~ 230/400-50Hz	DO 100 90	1080	940	G1"1/2	181.7	FB 50 / FC 50
DO 300 MV 160R	300	MV 160R	3 ~ 230/400-50Hz	DO 100 90	988	940	G1"1/2	186.3	FB 50 / FC 50

Note: By adding the letters SR, the pumpset will be supplied with wheels (E.g.: DO 300 MV 100 SR).

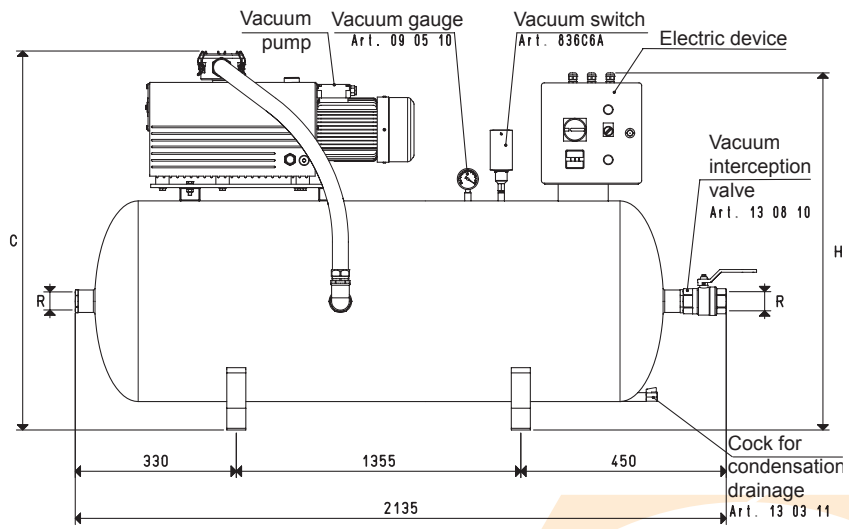
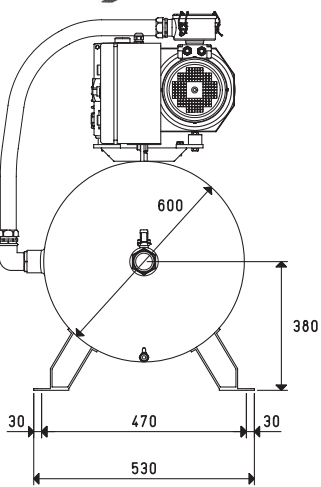
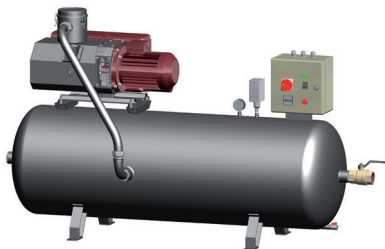

Art.	Tank	Pump	Motor execution	Switchgear	C	H	R	Weight	Filter accessories
	Litres	Mod.	Volt	art.			∅		Kg
DO 500 MV 100	500	MV 100	3 ~ 230/400-50Hz	DO 100 90	1060	1010	G2"	232.2	FB 60 / FC 60
DO 500 VTL 105/G1	500	VTL 105/G1	3 ~ 230/400-50Hz	DO 100 90	1180	1010	G2"	249.8	FB 60 / FC 60
DO 500 MV 160R	500	MV 160R	3 ~ 230/400-50Hz	DO 100 90	1198	1010	G2"	273.8	FB 60 / FC 60
DO 500 MV 200R	500	MV 200R	3 ~ 230/400-50Hz	DO 100 91	1220	1010	G2"	303.2	FB 60 / FC 60
DO 500 MV 300R	500	MV 300R	3 ~ 400/690-50Hz	DO 100 91	1220	1010	G2"	333.2	FB 60 / FC 60

Note: As a standard, all MV... pumps are equipped with an FC... filtre adjusted to the suction connection size.

Conversion ratio: inch = $\frac{\text{mm}}{25.4}$; pounds = $\frac{\text{g}}{453.6}$ = $\frac{\text{Kg}}{0.4536}$

GAS-NPT thread adapters available at page 1.117

7.75

HORIZONTAL PUMPSETS DO 1000 ...

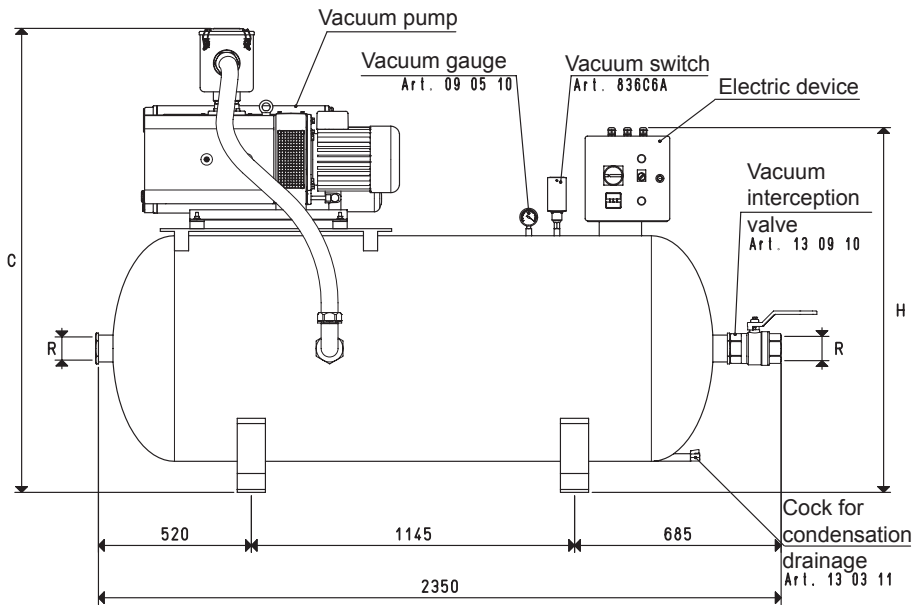
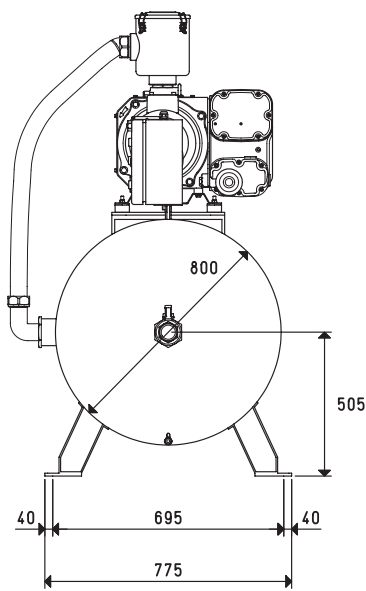
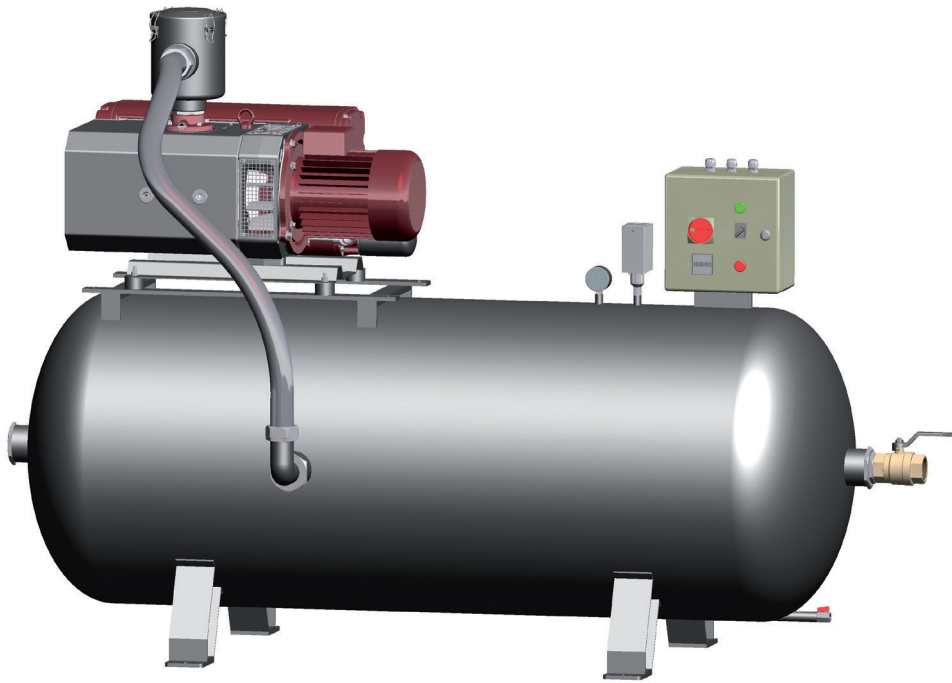

3D drawings available at www.vuototecnica.net

Art.	Tank	Pump	Motor execution	Switchgear	C	H	R	Weight	Filter accessories
	Litres	Mod.	Volt	art.			Ø	Kg	art.
DO 1000 MV 200R	1000	MV 200R	3 ~ 230/400-50Hz	DO 100 91	1541	1250	G3"	405	FC 80
DO 1000 MV 300R	1000	MV 300R	3 ~ 400/690-50Hz	DO 100 91	1541	1250	G3"	432	FC 80

Note: As a standard, all MV... pumps are equipped with an FC... filtre adjusted to the suction connection size.

7.76

Conversion ratio: inch = $\frac{\text{mm}}{25.4}$, pounds = $\frac{\text{g}}{453.6}$ = $\frac{\text{Kg}}{0.4536}$

GAS-NPT thread adapters available at page 1.117